

Approval body for construction products  
and types of construction

Bautechnisches Prüfamt

An institution established by the Federal and  
Laender Governments



## European Technical Assessment

ETA-11/0192  
of 22 January 2020

English translation prepared by DIBt - Original version in German language

### General Part

Technical Assessment Body issuing the  
European Technical Assessment:

Deutsches Institut für Bautechnik

Trade name of the construction product

EJOT H1 eco and EJOT H4 eco

Product family  
to which the construction product belongs

Nailed-in plastic anchor for fixing of external thermal  
insulation composite systems with rendering in concrete  
and masonry

Manufacturer

EJOT Baubefestigungen GmbH  
In der Stockwiese 35  
57334 Bad Laasphe  
DEUTSCHLAND

Manufacturing plant

EJOT manufacturing plant 1, 2, 3, 4

This European Technical Assessment  
contains

18 pages including 3 annexes which form an integral part  
of this assessment

This European Technical Assessment is  
issued in accordance with Regulation (EU)  
No 305/2011, on the basis of

EAD 330196-01-0604

This version replaces

ETA-11/0192 issued on 5 January 2018

The European Technical Assessment is issued by the Technical Assessment Body in its official language. Translations of this European Technical Assessment in other languages shall fully correspond to the original issued document and shall be identified as such.

Communication of this European Technical Assessment, including transmission by electronic means, shall be in full. However, partial reproduction may only be made with the written consent of the issuing Technical Assessment Body. Any partial reproduction shall be identified as such.

This European Technical Assessment may be withdrawn by the issuing Technical Assessment Body, in particular pursuant to information by the Commission in accordance with Article 25(3) of Regulation (EU) No 305/2011.

**Specific Part**

**1 Technical description of the product**

The nailed-in anchors EJOT H1 eco and EJOT H4 eco consist of an anchor sleeve with an enlarged shaft, spreading zone subsequently, an insulation plate made of virgin polyethylene, a mounting plug made of polyamide and accompanying specific nail of galvanised steel. For the anchor length of 95 mm (only H1 eco) and for the anchor length of 115 – 135 mm (only H4 eco) the accompanying specific nail of galvanised steel may have an overmoulding of polyamide. The serrated expanding part of the anchor sleeve is slotted.

The anchor may in addition be combined with the anchor plates SBL 140 plus and VT 90.

An illustration and the description of the product are given in Annex A.

**2 Specification of the intended use in accordance with the applicable European Assessment Document**

The performances given in Section 3 are only valid if the anchor is used in compliance with the specifications and conditions given in Annex B.

The verification and assessment methods on which this European Technical Assessment is based lead to the assumption of a working life of the anchor of at least 25 years. The indications given on the working life cannot be interpreted as a guarantee given by the producer, but are to be regarded only as a means for choosing the right products in relation to the expected economically reasonable working life of the works.

**3 Performance of the product and references to the methods used for its assessment**

**3.1 Safety and accessibility in use (BWR 4)**

Essential characteristic	Performance
Characteristic tension resistance	See Annex C 1
Edge distances and spacing	See Annex B 2
Plate stiffness	See Annex C 2, C 3
Displacements	See Annex C 2, C 3

**3.2 Energy economy and heat retention (BWR 6)**

Essential characteristic	Performance
Point thermal transmittance	See Annex C 2, C 3

**4 Assessment and verification of constancy of performance (AVCP) system applied, with reference to its legal base**

In accordance with EAD No. 330196-01-0604, the applicable European legal act is: [97/463/EC].

The system to be applied is: 2+

**5 Technical details necessary for the implementation of the AVCP system, as provided for in the applicable EAD**

Technical details necessary for the implementation of the AVCP system are laid down in the control plan deposited with Deutsches Institut für Bautechnik.

Issued in Berlin on 22 January 2020 by Deutsches Institut für Bautechnik

BD Dipl.-Ing. Andreas Kummerow  
Head of Department

*beglaubigt:*  
Ziegler

**EJOT H1 eco**

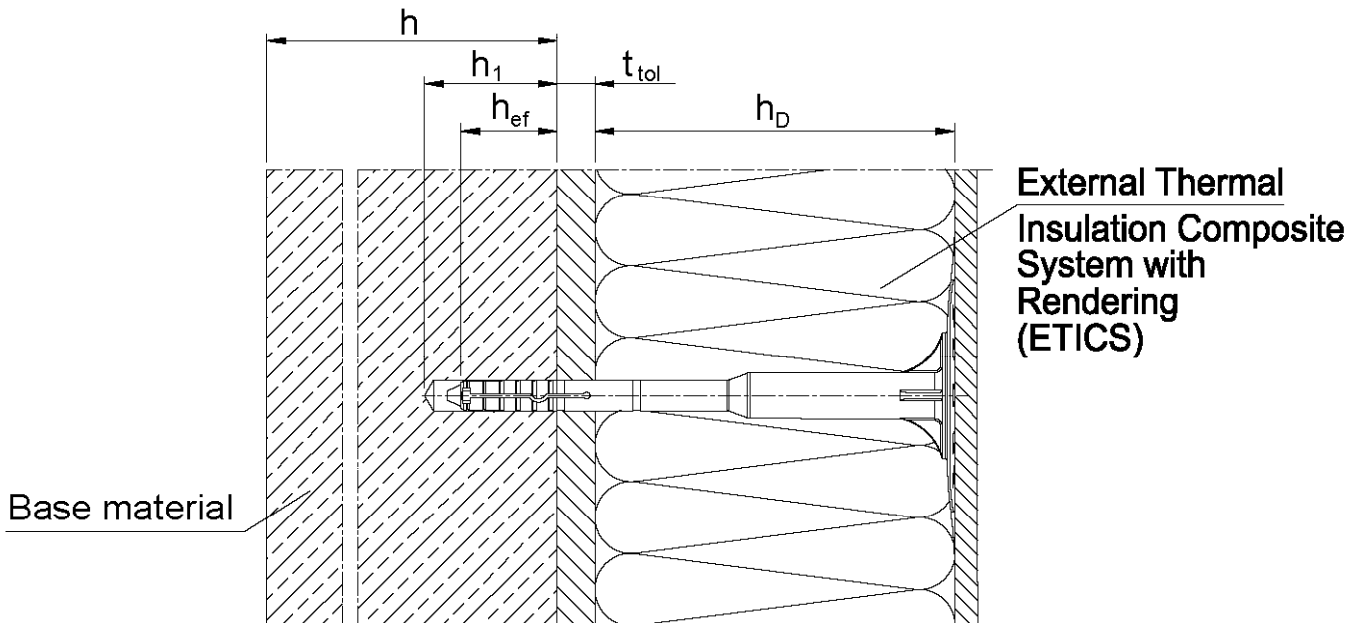

**Intended use**

- Anchorage of ETICS in concrete and masonry
- Anchorage of ETICS in autoclaved aerated concrete and lightweight aggregate concrete

Legend:

- $h_D$  = thickness of insulation material
- $h_{ef}$  = effective anchorage depth
- $h$  = thickness of member (wall)
- $h_1$  = depth of drilled hole to deepest point
- $t_{tol}$  = thickness of equalizing layer or non-load-bearing coating

**EJOT H1 eco and EJOT H4 eco**

**Product description**  
Installed condition EJOT H1 eco

**Annex A 1**

**EJOT H4 eco**

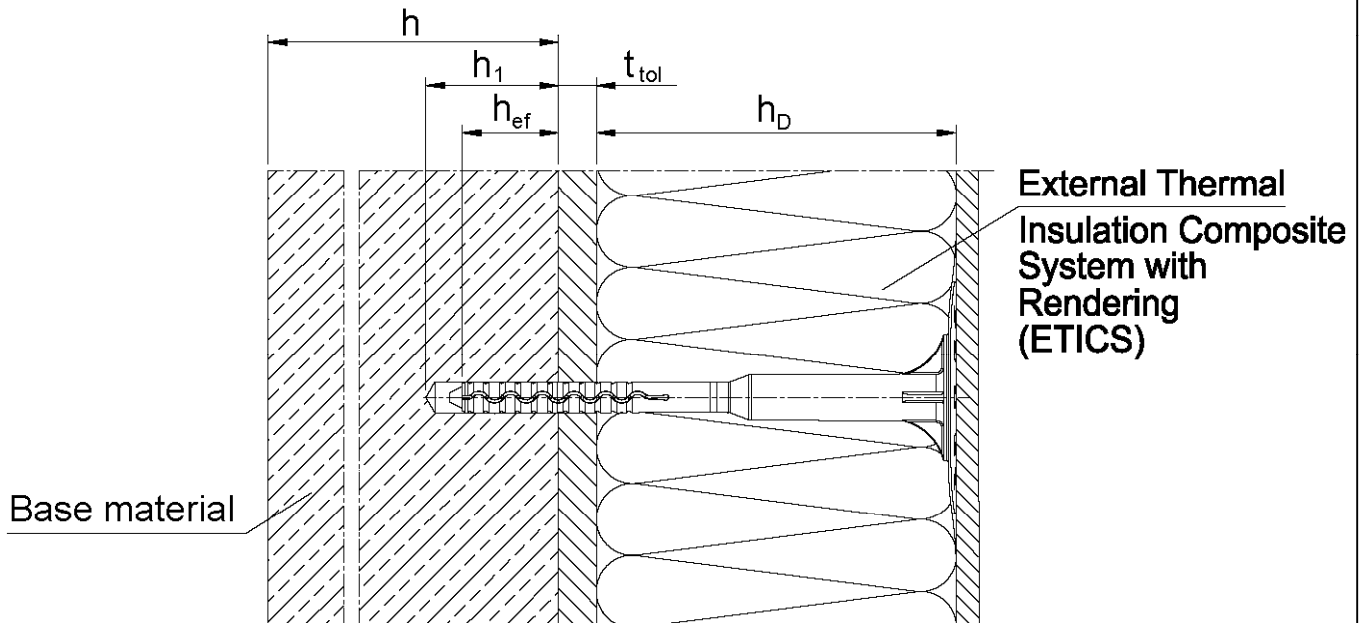

**Intended use**

- Anchorage of ETICS in concrete and masonry
- Anchorage of ETICS in autoclaved aerated concrete and lightweight aggregate concrete

**Legend:**

- $h_D$  = thickness of insulation material
- $h_{ef}$  = effective anchorage depth
- $h$  = thickness of member (wall)
- $h_1$  = depth of drilled hole to deepest point
- $t_{tol}$  = thickness of equalizing layer or non-load-bearing coating

**EJOT H1 eco and EJOT H4 eco**

**Product description**

Installed condition EJOT H4 eco

**Annex A 2**

**EJOT H1 eco / use category: A, B, C**

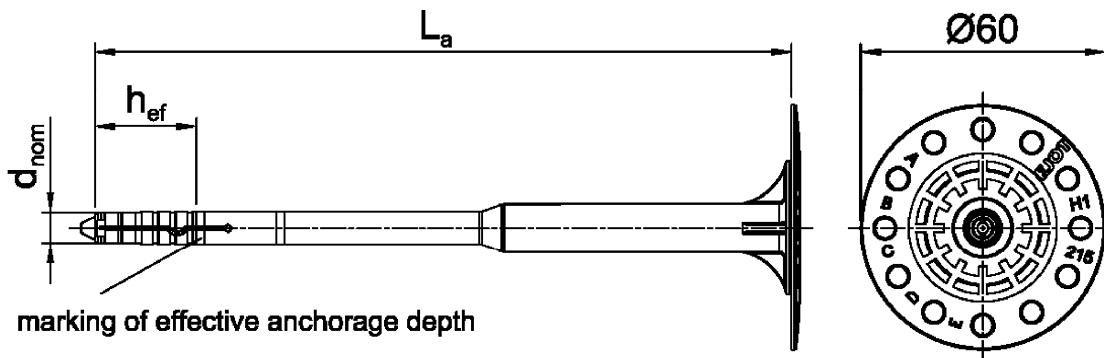

marking of effective anchorage depth

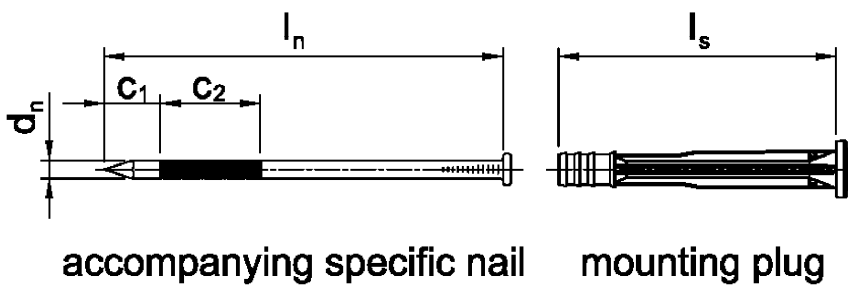

accompanying specific nail

mounting plug

**Marking:**  
Identifying mark (EJOT)  
Anchor type (H1 eco)  
Length of anchor (e.g. 175)

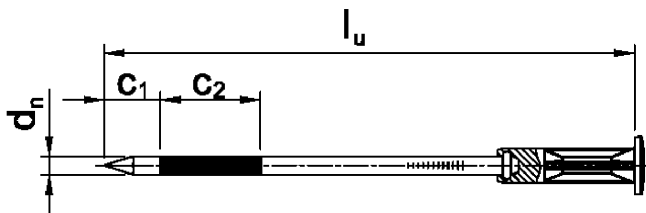

**Length of anchor 95mm: accompanying specific nail with overmolding**

**Table A1: Dimensions**

Anchor Type	Anchor Sleeve			Mounting Plug min L <sub>s</sub> max L <sub>s</sub> [mm]	Specific nail				
	d <sub>nom</sub> [mm]	h <sub>ef</sub> [mm]	min L <sub>a</sub> max L <sub>a</sub> [mm]		d <sub>n</sub> [mm]	c <sub>1</sub> [mm]	c <sub>2</sub> [mm]	min l <sub>n</sub> max l <sub>n</sub> [mm]	l <sub>u</sub> [mm]
EJOT H1 eco	8	25	95 295	32 110	4,5	14	25	60 180	90

Determination of maximum thickness of insulation h<sub>D</sub> [mm] for EJOT H1 eco:

$$h_D = L_a - t_{tol} - h_{ef} \quad (L_a = \text{e.g. } 175; t_{tol} = 10)$$

e.G.  $h_D = 175 - 10 - 25$   
 $h_{Dmax} = 140$

**EJOT H1 eco and EJOT H4 eco**

**Product description**

Marking and dimension of the anchor sleeve EJOT H1 eco; use category: A, B, C  
Expansion element

**Annex A 3**

**EJOT H1 eco / use category: D and E**

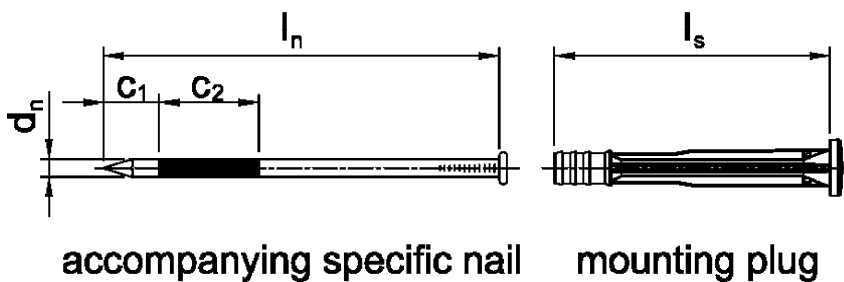
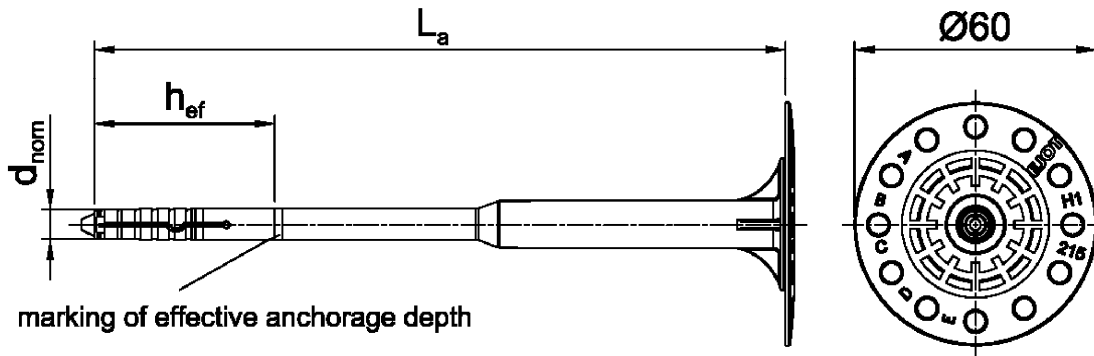

Marking:  
Identifying mark (EJOT)  
Anchor type (H1 eco)  
Length of anchor (e.g. 175)

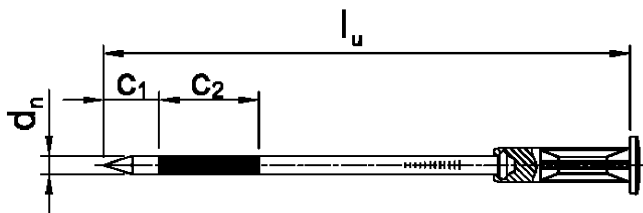

**Length of anchor 95mm: accompanying specific nail with overmolding**

**Table A2: Dimensions**

Anchor Type	Anchor Sleeve			Mounting Plug min L <sub>s</sub> max L <sub>s</sub> [mm]	Specific nail				
	d <sub>nom</sub> [mm]	h <sub>ef</sub> [mm]	min L <sub>a</sub> max L <sub>a</sub> [mm]		d <sub>n</sub> [mm]	c <sub>1</sub> [mm]	c <sub>2</sub> [mm]	min l <sub>n</sub> max l <sub>n</sub> [mm]	l <sub>u</sub> [mm]
EJOT H1 eco	8	45	95 295	32 110	4,5	14	25	60 180	90

Determination of maximum thickness of insulation h<sub>D</sub> [mm] for EJOT H1 eco:

$$h_D = L_a - t_{tol} - h_{ef} \quad (L_a = \text{e.g. } 175; t_{tol} = 10)$$

e.g.  $h_D = 175 - 10 - 45$

$$h_{Dmax} = 120$$

**EJOT H1 eco and EJOT H4 eco**

**Product description**

Marking and dimension of the anchor sleeve EJOT H1 eco; use category: D and E  
Expansion element

**Annex A 4**



**EJOT H4 eco / use category: A, B, C**

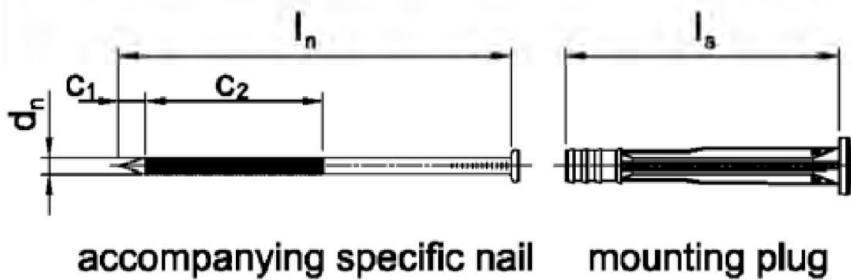
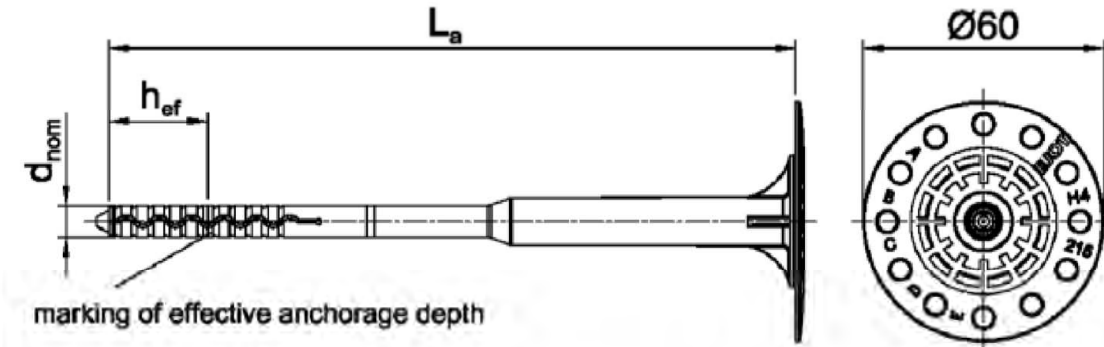

**Marking:**  
Identifying mark (EJOT)  
Anchor type (H4 eco)  
Length of anchor (e.g. 215)

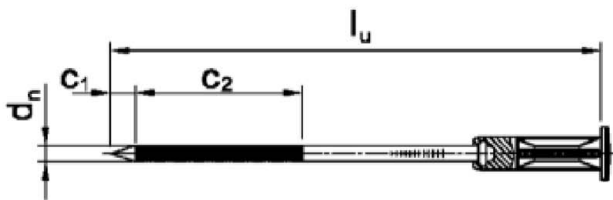

**Length of anchor 115mm - 135mm: accompanying specific nail with overmolding**

**Table A3: Dimensions**

Anchor type	Anchor sleeve			Mounting plug / overmolding	Specific nail				
	$d_{nom}$ [mm]	$h_{ef}$ [mm]	min $L_a$ max $L_a$ [mm]		min $L_s$ max $L_s$ [mm]	$d_n$ [mm]	$c_1$ [mm]	$c_2$ [mm]	min $l_n$ max $l_n$ [mm]
EJOT H4 eco	8	25	155 355	72 110	4,3	7	45	80 244	-
EJOT H4 eco	8	25	115 135	32	4,3	7	45	-	110 130

Determination of maximum thickness of insulation  $h_D$  [mm] for EJOT H4 eco:

e.g.  $h_D = L_a - t_{tol} - h_{ef}$  ( $L_a = \text{e.g. } 215; t_{tol} = 10$ )  
 $h_D = 215 - 10 - 45$   
 $h_{Dmax} = 180$

**EJOT H1 eco and EJOT H4 eco**

**Product description**

Marking and dimension of the anchor sleeve EJOT H4 eco, use category: A, B, C  
Expansion element

**Annex A 5**

**EJOT H4 eco / use category: D and E**

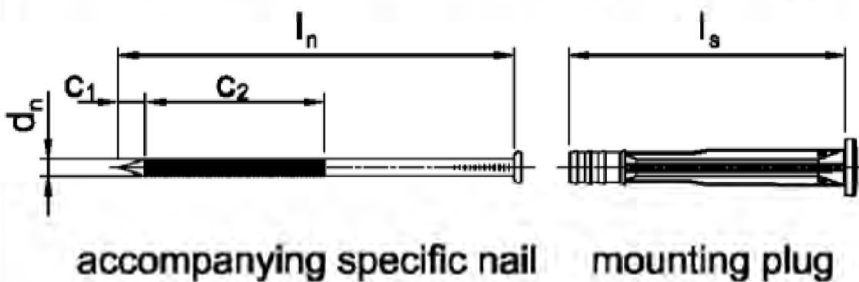
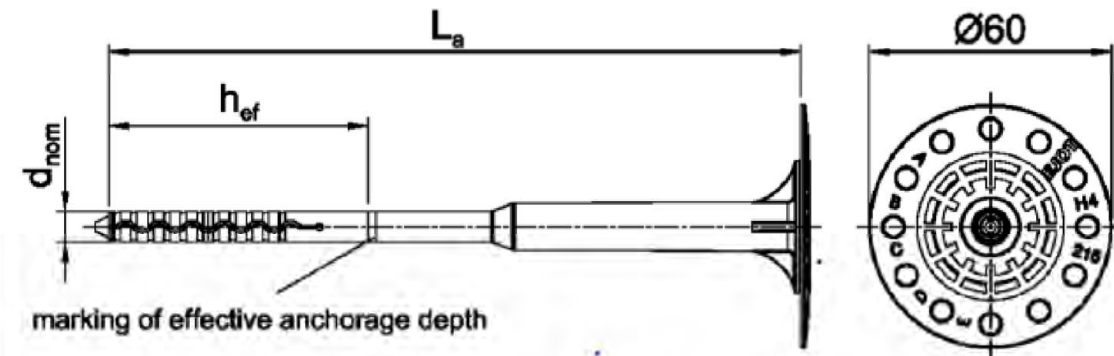

Marking:  
Identifying mark (EJOT)  
Anchor type (H4 eco)  
Length of anchor (e.g. 215)

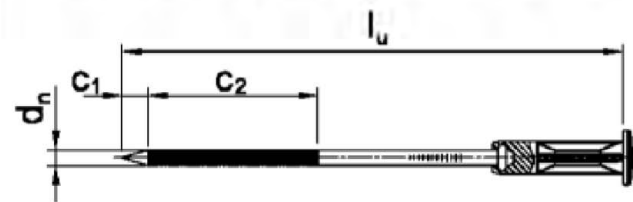

Length of anchor 115mm - 135mm: accompanying specific nail with overmolding

**Table A4: Dimensions**

Anchor type	Anchor sleeve			Mounting plug / overmoulding	Specific nail				
	$d_{nom}$ [mm]	$h_{ef}$ [mm]	min $L_a$ max $L_a$ [mm]		min $L_s$ max $L_s$ [mm]	$d_n$ [mm]	$c_1$ [mm]	$c_2$ [mm]	min $l_n$ max $l_n$ [mm]
EJOT H4 eco	8	65	155 355	72 110	4,3	7	45	80 244	-
EJOT H4 eco	8	65	115 135	32	4,3	7	45	-	110 130

Determination of maximum thickness of insulation  $h_D$  [mm] for EJOT H4 eco:

$$h_D = L_a - t_{tol} - h_{ef} \quad (L_a = \text{e.g. } 215; t_{tol} = 10)$$

e.g.  $h_D = 215 - 10 - 65$   
 $h_{Dmax} = 140$

**EJOT H1 eco and EJOT H4 eco**

**Product description**

Marking and dimension of the anchor sleeve EJOT H4 eco, use category: D and E  
Expansion element

**Annex A 6**

**Table A5: Materials**

Name	Materials
Anchor sleeve	virgin Polyethylene PE-HD colours: yellow, orange, red, blue, grey, nature, green
Mounting plug	Polyamide, PA GF 50
Specific nail	Steel, electro galvanized $\geq 5 \mu\text{m}$ according to EN ISO 4042:2018, blue passivated, $f_{yk} \geq 670 \text{ N/mm}^2$

**SBL 140 plus**

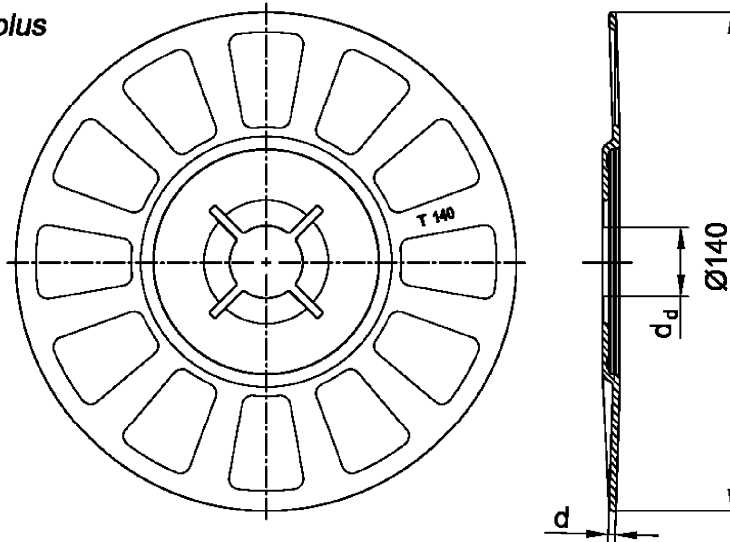

SBL 140 plus	
colour	nature
$d_d$ [mm]	20,0
$d$ [mm]	2,0
Material	<sup>1) 2)</sup>

**VT 90**

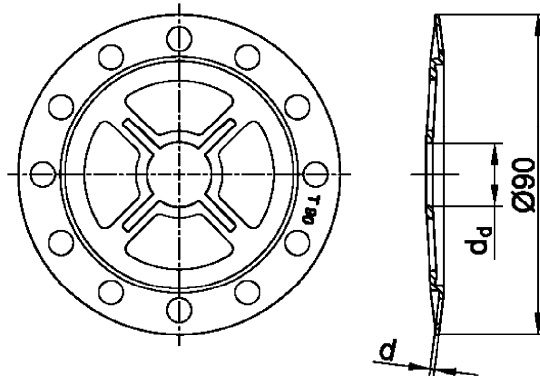

VT 90	
colour	nature
$d_d$ [mm]	17,5
$d$ [mm]	1,2
Material	<sup>1) 2)</sup>

- <sup>1)</sup> Polyamide, PA 6  
<sup>2)</sup> Polyamide, PA GF 50

**EJOT H1 eco and EJOT H4 eco**

**Product description**

Materials of EJOT H1 eco and EJOT H4 eco,  
Slip on plates with EJOT H1 eco and EJOT H4 eco

**Annex A 7**

## Specifications of intended use

### Anchorage subject to:

- The anchor may only be used for transmission of wind suction loads and shall not be used for the transmission of dead loads of the thermal insulation composite system.

### Base materials:

- Normal weight concrete (use category A) according to Annex C 1
- Solid masonry (use category B), according to Annex C 1
- Hollow or perforated masonry (use category C), according to Annex C 1
- Lightweight aggregate concrete (use category D), according to Annex C 1
- Autoclaved aerated concrete (use category E), according to Annex C 1
- For other base materials of the use categories A, B, C, D or E the characteristic resistance of the anchor may be determined by job site tests according to EOTA Technical Report TR 051 edition December 2016.

### Temperature Range:

- 0°C to +40°C (max. short term temperature +40°C and max. long term temperature +24°C)

### Design:

- The anchorages are designed under the responsibility of an engineer experienced in anchorages and masonry work with the partial safety factors  $\gamma_M = 2,0$  and  $\gamma_F = 1,5$ , if there are no other national regulations.
- Verifiable calculation notes and drawings are prepared taking account of the loads to be anchored. The position of the anchor is indicated on the design drawings.
- Fasteners are only to be used for multiple fixings of thermal insulation composite systems.

### Installation:

- Hole drilling by the drill modes according to Annex C 1
- Anchor installation carried out by appropriately qualified personnel and under the supervision of the person responsible for technical matters of the site
- Installation temperature from 0°C to +40°C
- Exposure to UV due to solar radiation of the anchor not protected by rendering  $\leq 6$  weeks

**EJOT H1 eco und EJOT H4 eco**

**Intended use**  
Specifications

**Annex B 1**

**Table B1: Installation parameters**

Anchor type		EJOT H1 eco		EJOT H4 eco	
		A B C	D and E	A B C	D and E
Drill hole diameter	$d_0$ [mm] =	8	8	8	8
Cutting diameter of drill bit	$d_{cut}$ [mm] ≤	8,45	8,45	8,45	8,45
Depth of drilled hole to deepest point	$h_1$ [mm] ≥	35	55	35	75
Effective anchorage depth	$h_{ef}$ [mm] ≥	25	45	25	65

**Table B2: Anchor distances and dimensions of members**

Anchor type		EJOT H1 eco / EJOT H4 eco
Minimum allowable spacing	$s_{min} \geq$ [mm]	100
Minimum allowable edge distance	$c_{min} \geq$ [mm]	100
Minimum thickness of member	$h \geq$ [mm]	100

Scheme of distance and spacing

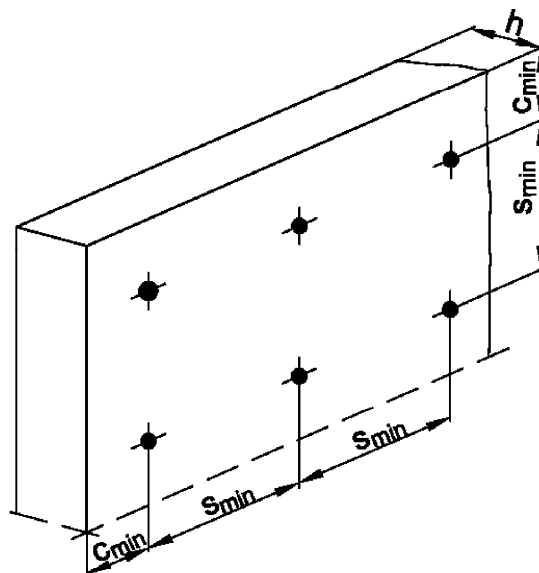

**EJOT H1 eco and EJOT H4 eco**

**Intended use**

Installations parameters,  
Edge distances and spacing

**Annex B 2**

### Installation instructions EJOT H1 eco

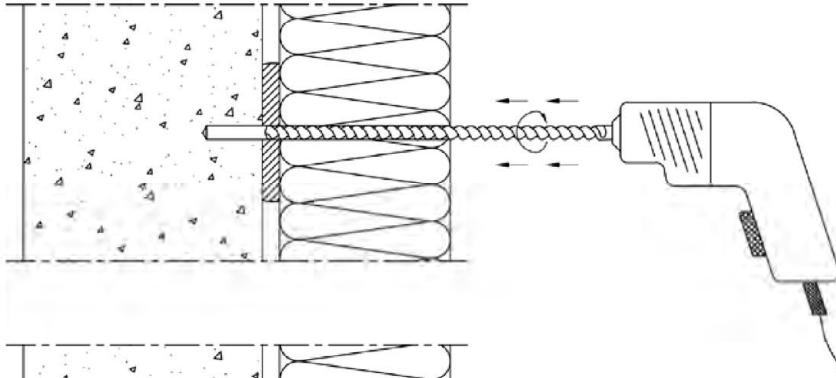

Drill the hole perpendicular to the substrate surface.  
Clean the drill hole 3x.

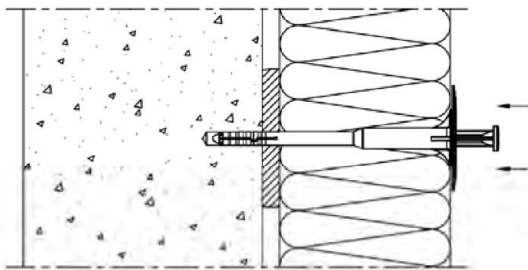

Place the anchor into the drill hole.  
The bottom side of the plate must be flush with the ETICS.

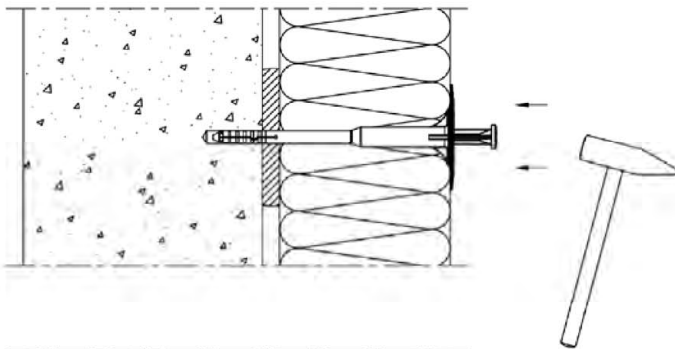

Drive in the specific nail with the hammer.

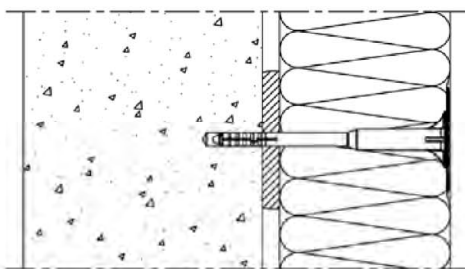

Installed condition of  
EJOT H1 eco.

**EJOT H1 eco and EJOT H4 eco**

**Intended use**

Installation instructions EJOT H1 eco

**Annex B 3**

### Installation instructions EJOT H4 eco

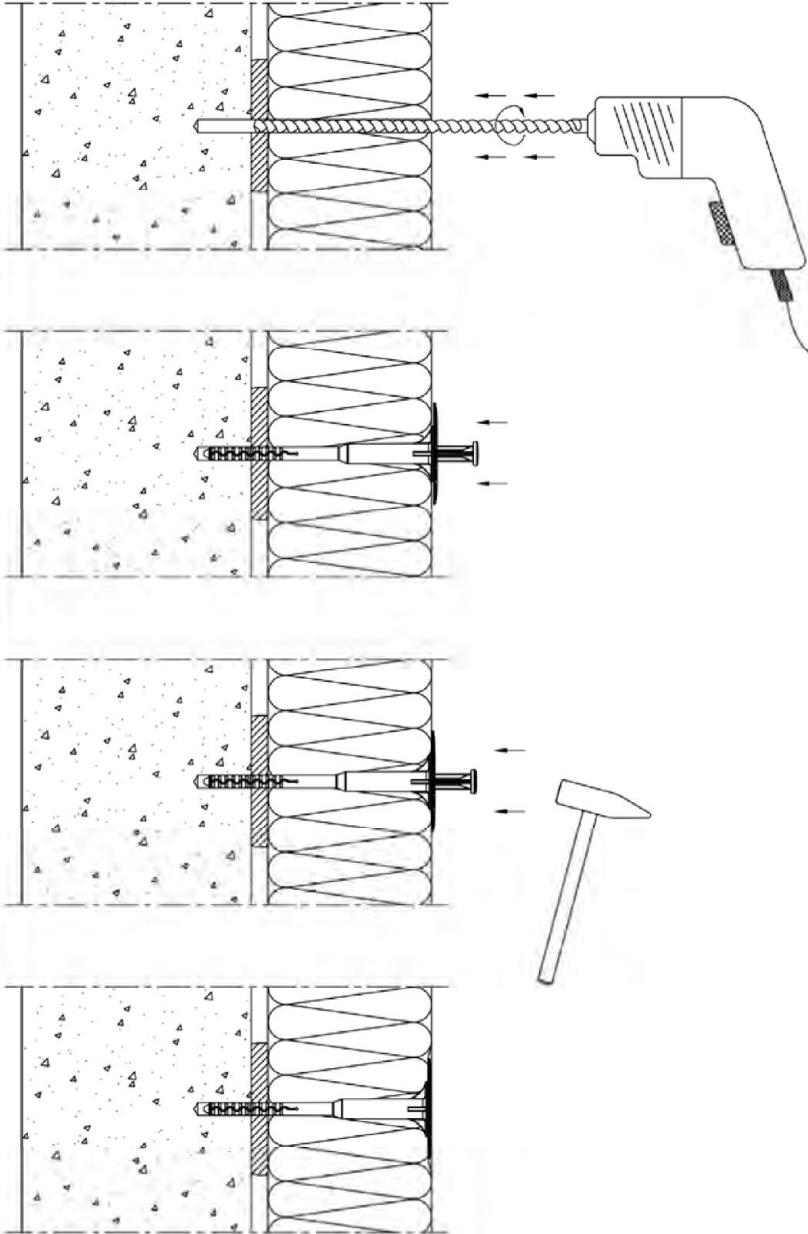

Drill the hole perpendicular to the substrate surface.  
Clean the drill hole 3x.

Place the anchor into the drill hole.  
The bottom side of the plate must be flush with the ETICS.

Drive in the specific nail with the hammer.

Installed condition of EJOT H4 eco.

EJOT H1 eco and EJOT H4 eco

**Intended use**  
Installation instructions EJOT H4 eco

**Annex B 4**

<b>Table C1: Characteristic resistance to tension loads <math>N_{Rk}</math> in concrete and masonry for a single anchor in kN</b>						EJOT H1 eco	EJOT H4 eco
Anchor type					$N_{Rk}$	$N_{Rk}$	
Base materials	Bulk density $\rho$ [kg/dm <sup>3</sup> ]	minimum compressive strength $f_b$ [N/mm <sup>2</sup> ]	General remarks	Drill method	[kN]	[kN]	
Concrete C12/15 EN 206-1:2000				hammer	0,90	0,50	
Concrete C25/25 – C50/60 EN 206-1:2000				hammer	0,90	0,75	
Clay bricks, Mz e.g. according to EN 771-1:2011	$\geq 1,8$	12	Vertically perforation up to 15 %	hammer	0,90	0,75	
Sand-lime solid bricks, KS e.g. according to EN 771-2:2011	$\geq 1,8$	12	Vertically perforation up to 15 %	hammer	0,90	0,75	
Vertically perforated clay bricks, HLz e.g. according to EN 771-1:2011	$\geq 1,2$	20	Vertically perforation more than 15 % and less than 50 %	rotary	0,75 <sup>1)</sup>	-	
Vertically perforated clay bricks, Hlz e.g. according to EN 771-1:2011	$\geq 0,9$	12	Vertically perforation more than 15 % and less than 50 %	rotary	0,60 <sup>2)</sup>	0,50 <sup>2)</sup>	
Sand-lime perforated bricks, KSL e.g. according to EN 771-2:2011	$\geq 1,4$	12	Vertically perforation more than 15 % and less than 50 %	rotary	0,9 <sup>3)</sup>	0,75 <sup>3)</sup>	
Lightweight aggregate concrete, LAC 4 – LAC 25 e.g. according to EN 1520:2011 / EN 771-3:2011	$\geq 1,2$	4		hammer	0,9	1,2	
Autoclaved aerated concrete, AAC 4 – AAC 7 e.g. according to EN 771-4:2011	$\geq 0,6$	4		rotary	0,5	0,5	
<b>EJOT H1 eco and H4 eco</b>					<b>Annex C 1</b>		
<b>Performances</b> Characteristic resistance							

<sup>1)</sup> The value applies only for outer web thickness  $\geq 14$  mm; otherwise the characteristic resistance shall be determined by job site pull-out tests.

<sup>2)</sup> The value applies only for outer web thickness  $\geq 11$  mm; otherwise the characteristic resistance shall be determined by job site pull-out tests.

<sup>3)</sup> The value applies only for outer web thickness  $\geq 20$  mm; otherwise the characteristic resistance shall be determined by job site pull-out tests.



### **EJOT H1 eco**

**Table C2: Point thermal transmittance according EOTA Technical Report TR 025:2016-05**

anchor type	insulation thickness $h_D$ [mm]	point thermal transmittance $\chi$ [W/K]
EJOT H1 eco	60 – 260	0,001

**Table C3: Plate stiffness according EOTA Technical Report TR 026:2016-05**

anchor type	diameter of the anchor plate [mm]	load resistance off the anchor plate [kN]	plate stiffness [kN/mm]
EJOT H1 eco	60	1,4	0,60

**Table C4: Displacements EJOT H1 eco**

Base materials	Bulk density $\rho$ [kg/dm <sup>3</sup> ]	Minimum Compressive strength $f_b$ [N/mm <sup>2</sup> ]	Tension load N [kN]	Displacements $\delta(N)$ [mm]
Concrete C12/15 – C50/60 (EN 206-1:2000 )			0,3	0,3
Clay bricks, Mz (EN 771-1:2011)	$\geq 1,8$	12	0,3	0,3
Sand-lime solid bricks, KS (EN 771-2:2011)	$\geq 1,8$	12	0,3	0,3
Vertically perforated clay bricks, HLz (EN 771-1:2011)	$\geq 1,2$	20	0,25	0,4
Vertically perforated clay bricks, HLz (EN 771-1:2011)	$\geq 0,9$	12	0,2	0,2
Sand-lime perforated bricks, KSL (EN 771-2:2011)	$\geq 1,4$	12	0,3	0,3
Lightweight aggregate concrete, LAC 4 – LAC 25 (EN 1520:2011 / EN 771-3:2011)	$\geq 1,2$	4	0,3	1,1
Autoclaved aerated concrete, AAC 4 – AAC 7 (EN 771-4:2011)	$\geq 0,6$	4	0,17	0,7

### **EJOT H1 eco and EJOT H4 eco**

#### **Performances**

Point thermal transmittance, plate stiffness, displacements for EJOT H1 eco

**Annex C 2**

### **EJOT H4 eco**

**Table C5: Point thermal transmittance according EOTA Technical Report TR 025:2016-05**

anchor type	insulation thickness $h_D$ [mm]	point thermal transmittance $\chi$ [W/K]
EJOT H4 eco	60 – 260	0,001

**Table C6: Plate stiffness according EOTA Technical Report TR 026:2016-05**

anchor type	diameter of the anchor plate [mm]	load resistance of the anchor plate [kN]	plate stiffness [kN/mm]
EJOT H4 eco	60	1,4	0,60

**Table C7: Displacements EJOT H4 eco**

Base materials	Bulk density $\rho$ [kg/dm <sup>3</sup> ]	Minimum Compressive strength $f_b$ [N/mm <sup>2</sup> ]	Tension load N [kN]	Displacements $\delta(N)$ [kN/mm]
Concrete C12/15 – C50/60 (EN 206-1:2000 )			0,3	0,6
Clay bricks, Mz (EN 771-1:2011)	$\geq 1,8$	12	0,25	0,4
Sand-lime solid bricks, KS (EN 771-2:2011)	$\geq 1,8$	12	0,25	0,4
Vertically perforated clay bricks, HLz (EN 771-1:2011)	$\geq 0,9$	12	0,15	0,6
Sand-lime perforated bricks, KSL (EN 771-2:2011)	$\geq 1,4$	12	0,25	0,4
Lightweight aggregate concrete, LAC 4 – LAC 25 (EN 1520:2011 / EN 771-3:2011)	$\geq 1,2$	4	0,4	1,3
Autoclaved aerated concrete, AAC 4 – AAC 7 (EN 771-4:2011)	$\geq 0,6$	4	0,17	0,6

### **EJOT H1 eco and EJOT H4 eco**

#### **Performances**

Point thermal transmittance, plate stiffness, displacements for EJOT H4 eco

**Annex C 3**