

Dimičeva 12,
1000 Ljubljana, Slovenija

Tel.: +386 (0)1 280 44 72, +386 (0)1-280 45 37

Fax: +386 (0)1 280 44 84

e-mail: info.ta@zag.si

<http://www.zag.si>

European Technical Assessment

ETA-18/0219
of 13.03.2020

English version prepared by ZAG

General Part

**Technical Assessment Body issuing the
European Technical Assessment:**

ZAG Ljubljana

**Trade name of the construction
product**

EJOT through bolts BA-V Plus/ BA-F
Plus/ BA-E Plus/ BA-E Plus HCR

**Product family to which the construction
product belongs**

33: Torque controlled expansion
anchor of sizes M8, M10, M12 and
M16 for use in concrete

Manufacturer

EJOT BAUBEFESTIGUNGEN GmbH
In der Stockwiese 35
57334 BAD LAASPHE
Germany
www.ejot.com

Manufacturing plant(s)

EJOT Plant 14

**This European Technical Assessment
contains**

17 pages including 14 Annexes which form
an integral part of this assessment

**This European Technical Assessment is
issued in accordance with Regulation (EU) No
305/2011, on the basis of**

EAD 330232-00-0601, edition
October 2016

This version replaces

ETA-18/0219 issued on 07.05.2019

Translations of this European Technical Assessment in other languages shall fully correspond to the original issued document and should be identified as such.

Communication of this European Technical Assessment, including transmission by electronic means, shall be in full (excepted the confidential Annex(es) referred to above). However, partial reproduction may be made, with the written consent of the issuing Technical Assessment Body. Any partial reproduction has to be identified as such.



Specific parts

1 Technical description of the product

The EJOT through bolts BA-V Plus/ BA-F Plus/ BA-E Plus/ BA-E Plus HCR is an anchor made of zinc plated carbon steel (BA-V Plus), hot dip galvanized carbon steel (BA-F Plus), stainless steel (BA-E Plus) and high corrosion resistant stainless steel (BA-E Plus HCR). It consists of a bolt, expansion sleeve, hexagonal nut and washer.

Anchors are made in sizes M8, M10, M12 and M16. Anchor is placed into a drilled hole and anchored by torque-controlled expansion.

For the installed anchor see Figure given in Annex A1.

2 Specification of the intended use(s) in accordance with the applicable European Assessment Document (hereinafter EAD)

The performances given in Chapter 3 are only valid if the anchor is used in compliance with the specifications and conditions given in Annex B.

The provisions made in this European Technical Assessment are based on an assumed working life of the anchor of 50 years. The indications given on the working life cannot be interpreted as a guarantee given by the manufacturer, but are to be regarded only as a means for choosing the right products in relation to the expected economically reasonable working life of the works.

3 Performance of the product and references to the methods used for its assessment

3.1 Mechanical resistance and stability (BWR 1)

The basic work requirements for mechanical resistance and stability are listed in Annexes C1 and C2 for static and quasi-static loading and in Annexes C6 and C7 for seismic performance.

3.2 Safety in case of fire (BWR 2)

The basic work requirements for safety in case of fire are listed in Annexes C3 and C4.

3.3 General aspects relating to fitness for use

Durability and serviceability are only ensured if specifications of intended use according to Annex B1 are kept.



4 Assessment and verification of constancy of performance (hereinafter AVCP) system applied, with reference to its legal base

According to the decision 96/582/EC of the European Commission¹ the system of assessment and verification of constancy of performance (see Annex V to regulation (EU) No 305/2011) **1** apply.

5 Technical details necessary for the implementation of the AVCP system, as provided for on the applicable EAD

Technical details necessary for the implementation of the AVCP system are laid down in chapter 3 of EAD 330232-00-0601.

Issued in Ljubljana on 13.03.2020

Signed by:
Franc Capuder, M.Sc.
Head of Service of TAB



¹ Official Journal of the European Communities L 254 of 8.10.1996
ETA-18/0219, issued on 13.03.2020 – page 3 of 17

EJOT through bolt

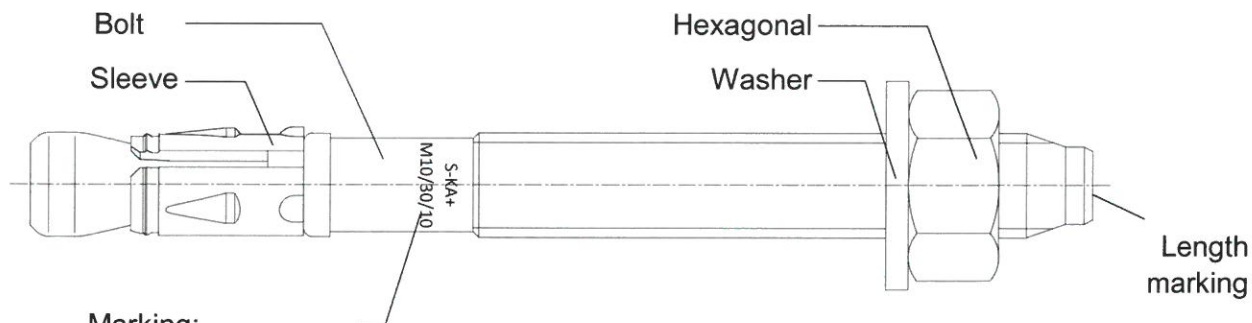

Marking:

BA-V Plus:	S-KA+ M.../t _{fix,max} /t _{fix,min}	- zinc plated
BA-F Plus:	S-KAK+ M.../t _{fix,max} /t _{fix,min}	- hot dip galvanized
BA-E Plus:	S-KAH+ M.../t _{fix,max} /t _{fix,min}	- stainless steel A4
BA-E Plus HCR:	S-KAH+ HCR M.../t _{fix,max} /t _{fix,mi}	- high corrosion resistant stainless steel

Length marking:

Length marking	A	B	C	D	E	F
Length (mm)	38,1-50,8	50,8-63,5	63,5-76,2	76,2-88,9	88,9-101,6	101,6-114,3

Length marking	G	H	I	J	K
Length (mm)	114,3-127,0	127,0-139,7	139,7-152,4	152,4-165,1	165,1-177,8

Length marking	L	M	N	O	P
Length (mm)	177,8-190,5	190,5-203,2	203,2-215,9	215,9-228,6	228,6-241,3

Length marking	Q	R	S
Length (mm)	241,3-254,0	254,0-279,4	279,4-304,8

**EJOT through bolts BA-V Plus/ BA-F Plus/ BA-E Plus/
BA-E Plus HCR**

Product description

Product



Annex A1

EJOT through bolt after installation

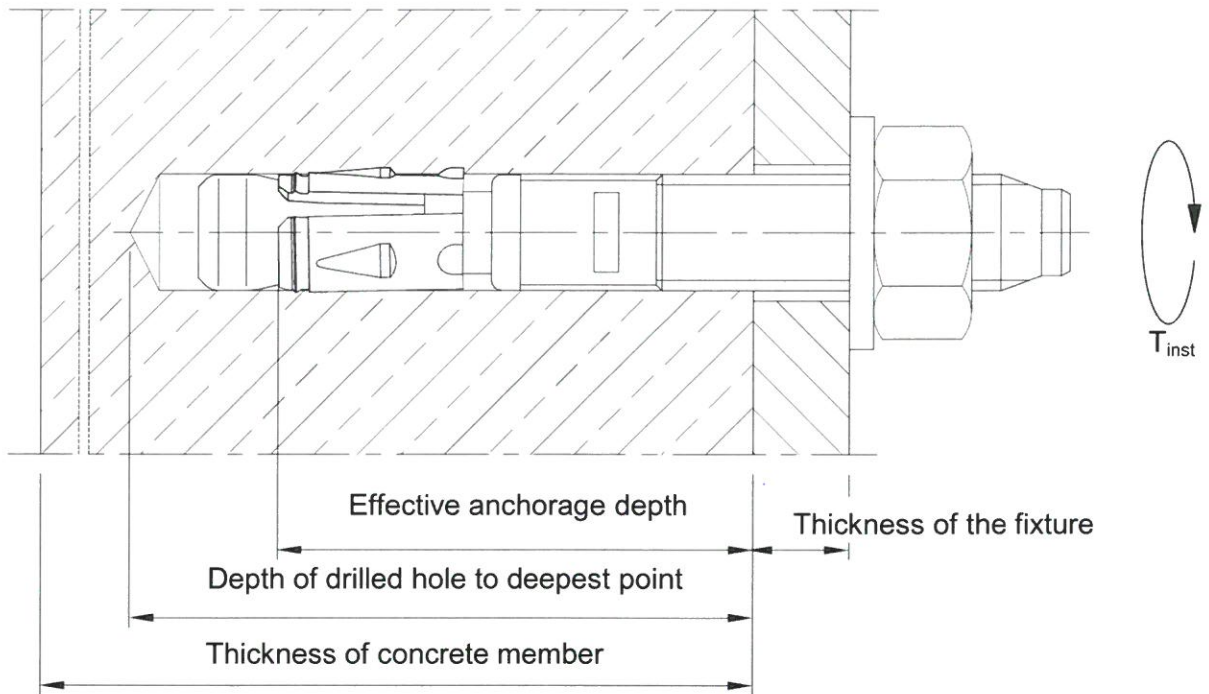

**EJOT through bolts BA-V Plus/ BA-F Plus/ BA-E Plus/
BA-E Plus HCR**

Product description
Installation condition



Annex A2

EJOT through bolt

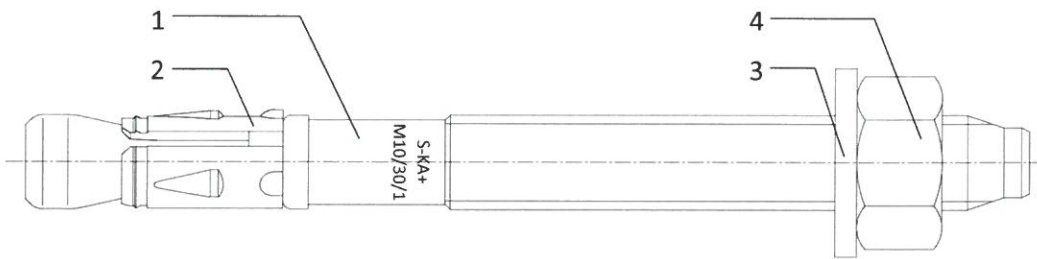

Table A1: Materials for BA-V Plus and BA-F Plus

Part	Designation	Material ^{1) 2)}
1	Bolt	Cold forged carbon steel, EN 10263-2
2	Sleeve	Cold rolled galvanized steel strip, EN 10346 or stainless strip, EN 10088-2
3	Washer	Steel, DIN 125 (EN ISO 7089), DIN 440 (EN ISO 7094), DIN 9021 (EN ISO 7093)
4	Hexagonal nut	Steel, electroplated, property class 8, DIN 934 (EN ISO 4032)

¹⁾ **BA-V Plus:** Parts 1,3 and 4 are zinc electroplated according to EN ISO 4042 $\geq 5\mu\text{m}$ and bright passivated

²⁾ **BA-F Plus:** Parts 1,3 and 4 are hot dip galvanized according to EN ISO 10684 $\geq 50\mu\text{m}$

Table A2: Materials for BA-E Plus

Part	Designation	Material
1	Bolt	Cold forged stainless steel, EN 10088-3
2	Sleeve	Stainless steel strip, EN 10088-2
3	Washer	Stainless steel, DIN 125 (EN ISO 7089), DIN 440 (EN ISO 7094), DIN 9021 (EN ISO 7093)
4	Hexagonal nut	Stainless steel, property class 80, DIN 934 (EN ISO 4032)

Table A3: Materials for BA-E Plus HCR

Part	Designation	Material
1	Bolt	Cold forged stainless steel, EN 10088-3 1.4529/1.4565
2	Sleeve	Stainless steel strip, EN 10088-2
3	Washer	Stainless steel, W 1.4529 / 1.4565, DIN 125 (EN ISO 7089), DIN 440 (EN ISO 7094), DIN 9021 (EN ISO 7093)
4	Hexagonal nut	Stainless steel, property class 70, W 1.4529 / 1.4565 DIN 934 (EN ISO 4032)

**EJOT through bolts BA-V Plus/ BA-F Plus/ BA-E Plus/
BA-E Plus HCR**

Product description
Materials

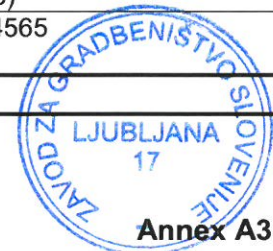

Specifications of intended use

Anchorage subjected to:

- Static, quasi static and seismic load,
- fire exposure.

Base materials:

- Cracked and non-cracked concrete.
- Reinforced and unreinforced normal weight concrete of strength class C20/25 at minimum and C50/60 at maximum according to EN 206:2013+A1:2016.

Use conditions (Environmental conditions):

- The BA-V Plus and BA-F Plus anchors may be used in concrete subject to dry internal conditions.
- The BA-E Plus anchors may be used in concrete subject to dry internal conditions and also in concrete subject to external atmospheric exposure (including industrial and marine environment), or exposure in permanently damp internal conditions, if no particular aggressive conditions exist.
- The BA-E Plus HCR anchors may be used in concrete subject to dry internal conditions and also in concrete subject to external atmospheric exposure, in permanently damp internal conditions or in other particular aggressive conditions.

Note: Particular aggressive conditions are e.g. permanent, alternating immersion in seawater or the splash zone of seawater, chloride atmosphere of indoor swimming pools or atmosphere with extreme chemical pollution (e.g. desulphurization plants or road tunnels where de-icing materials are used).

Design:

- Anchorages are designed under the responsibility of an engineer experienced in anchorages and concrete work.
- Anchorages under static and quasi-static actions are designed in accordance with EOTA TR 055, Edition December 2016 or EN 1992-4:2018.
- For seismic application the anchorages are designed in accordance with EOTA TR 045 "Design of metal anchors for use in concrete under seismic actions".
- For application with resistance under fire exposure the anchorages are designed in accordance with the method given in EOTA TR 020, Edition May 2004.
- Verifiable calculation notes and drawings are prepared taking into account of the load to be anchored. The position of the anchor is indicated on the design drawings (e.g. position of the anchor relative to reinforcement or to supports, etc.).

Installation:

- Anchor installation carried out by appropriately qualified personnel and under the supervision of the person responsible for technical matters on the site.
- Use of the anchor only as supplied by the manufacturer without exchanging the components of an anchor.
- Anchor installation in accordance with the manufacturer's specifications and drawings using the appropriate tools.
- Checks before placing the anchor to ensure that the strength class of the concrete in which the anchor is to be placed is in the range given and is not lower than that of the concrete to which the characteristic loads apply for.
- Check of concrete being well compacted, e.g. without significant voids.
- Cleaning of the hole of drilling dust.
- Anchor installation ensuring the specified embedment depth.
- Keeping of the edge distance and spacing to the specified values without minus tolerances.
- In case of aborted hole, drilling of new hole at a minimum distance of twice the depth of the aborted hole, or smaller distance provided the aborted drill hole is filled with high strength non-shrinkage mortar. No shear or oblique tension loads are allowed in the direction of a not filled aborted hole.
- Application of the torque moment given in Annex B2 using a calibrated torque wrench.

**EJOT through bolts BA-V Plus/ BA-F Plus/ BA-E Plus/
BA-E Plus HCR**

**Intended use
Specifications**

Annex B1

EJOT through bolt

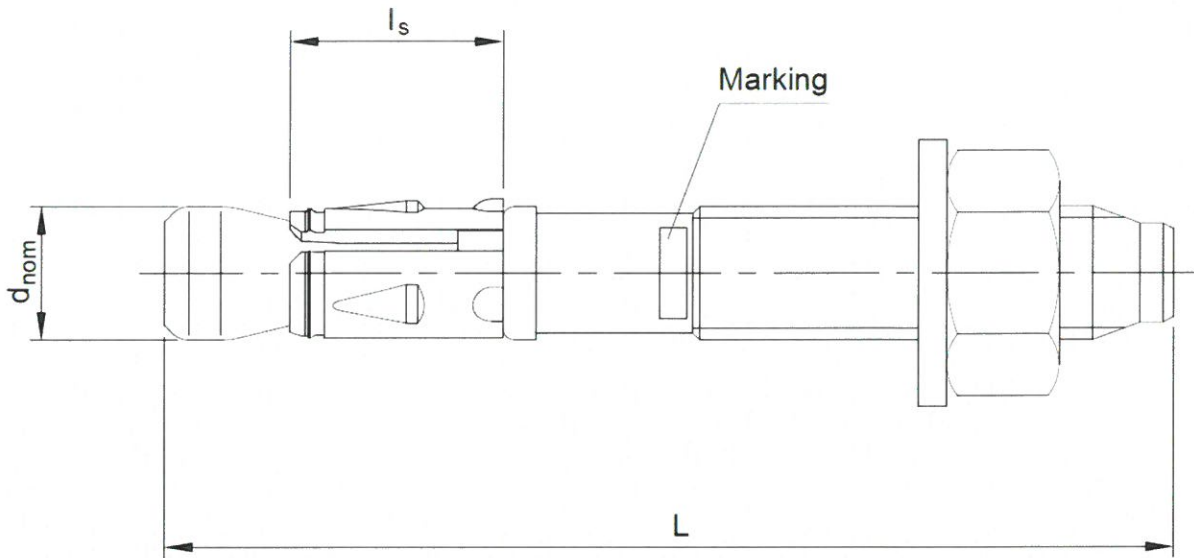

Table B1: Dimension of an anchor

Size	Nominal diameter d_{nom} [mm]	Sleeve length l_s [mm]	Total length L [mm]
M8	8	14,8	62 ... 420
M10	10	17,9	62 ... 420
M12	12	19,1	78 ... 420
M16	16	26,0	118 ... 420

**EJOT through bolts BA-V Plus/ BA-F Plus/ BA-E Plus/
BA-E Plus HCR**

Intended use
Anchor dimensions



Annex B2

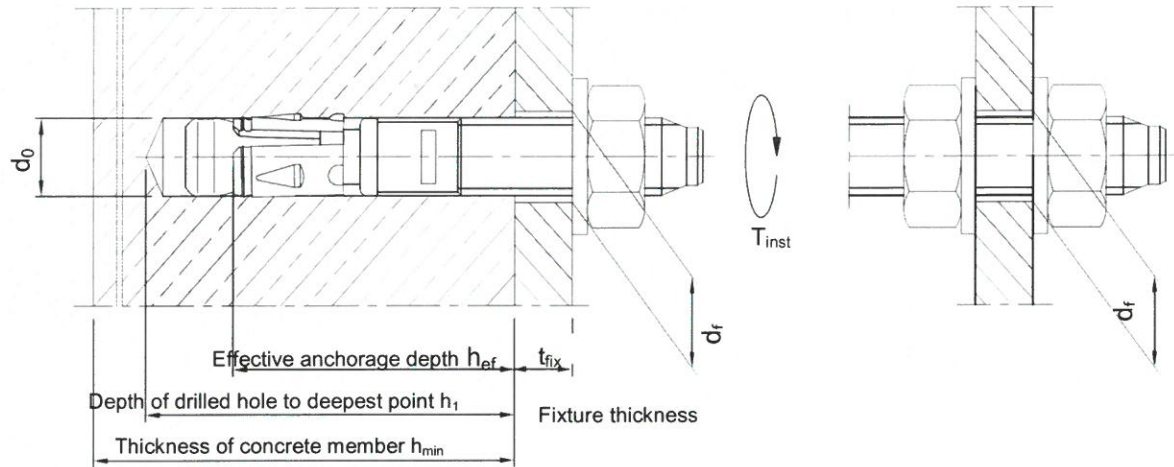

Table B2: Installation data

EJOT through bolts BA-V Plus/ BA-F Plus/ BA-E Plus/ BA-E Plus HCR		Anchor size					
		M8	M10- red	M10	M12- red	M12	M16
Drill hole diameter	d_0 [mm]	8	10	10	12	12	16
Cutting diameter at the upper tolerance limit (maximum diameter bit)	$d_{cut,max} \leq$ [mm]	8,45	10,45	10,45	12,50	12,50	16,50
Depth of drilled hole to deepest point	$h_1 \geq$ [mm]	60	55	75	70	90	110
Effective anchorage depth	h_{ef} [mm]	48	40	60	50	70	85
Diameter of clearance hole in the fixture	$d_f \leq$ [mm]	9	12	12	14	14	18
Thickness of the fixture	$t_{fix,max}$ [mm]	358	358	338	342	322	302
Required torque BA-V Plus/ BA-F Plus	T_{inst} [Nm]	15	30	30	60	60	110
BA-E Plus/ BA-E Plus HCR		20	45	45	60	60	110



**EJOT through bolts BA-V Plus/ BA-F Plus/ BA-E Plus/
BA-E Plus HCR**

Intended use
Installation data

Annex B3

Table B3: Minimum thickness of concrete member, spacing and edge distance

EJOT through bolts BA-V Plus/ BA-F Plus/ BA-E Plus/ BA-E Plus HCR		Anchor size					
		M8	M10- red	M10	M12- red	M12	M16
Minimum thickness of concrete member	h_{min} [mm]	100	100	120	100	140	170
	$h_{min-red}$ [mm]	80	/	100	/	/	/
Minimum spacing for h_{min}	s_{min} [mm]	35	50	40	55	60	65
	$c \geq$ [mm]	50	95	60	110	70	95
Minimum edge distance for h_{min}	c_{min} [mm]	40	50	50	60	55	65
	$s \geq$	55	190	100	215	110	150
Minimum spacing for $h_{min-red}$	s_{min} [mm]	35	/	40	/	/	/
	$c \geq$ [mm]	55	/	100	/	/	/
Minimum edge distance for $h_{min-red}$	c_{min} [mm]	40	/	60	/	/	/
	$s \geq$	60	/	90	/	/	/

**EJOT through bolts BA-V Plus/ BA-F Plus/ BA-E Plus/
BA-E Plus HCR**

Intended use
Installation data



Annex B4

Table C1: Characteristic resistances under tension loads in case of static and quasi-static loading for design according EOTA TR 055 or **EN 1992-4:2018**

EJOT through bolts BA-V Plus/ BA-F Plus/ BA-E Plus/ BA-E Plus HCR				Anchor size					
				M8	M10- red	M10	M12- red	M12	M16
Steel failure									
Characteristic resistance	BA-V Plus/ BA-F Plus	$N_{Rk,s}$	[kN]	15	26	26	39	39	73
	BA-E Plus/ BA-E Plus HCR			15	26	26	40	40	73
Partial safety factor		$\gamma_{Ms}^{2)}$	[-]	1,4					
Pull-out failure									
Characteristic resistance in cracked concrete C20/25		$N_{Rk,p}$	[kN]	8,5	1)	12	1)	16	24
Characteristic resistance in non-cracked concrete C20/25		$N_{Rk,p}$	[kN]	11	12	19	1)	25	36
Increasing factor for $N_{Rk,p}$		Ψ_C	C25/30	1,09	1,12	1,07	1,12	1,11	1,10
			C30/37	1,17	1,22	1,13	1,22	1,21	1,18
			C35/45	1,23	1,32	1,17	1,32	1,29	1,25
			C40/50	1,30	1,41	1,23	1,41	1,38	1,32
			C45/55	1,37	1,50	1,28	1,50	1,46	1,39
			C50/60	1,43	1,58	1,33	1,58	1,53	1,46
Partial safety factor		$\gamma_{inst}^{2)}$	[-]	1,0					
		$\gamma_{Mp}^{3)}$	[-]	1,5 ³⁾					
Concrete cone and splitting failure									
Effective anchorage depth		h_{ef}	[mm]	48	40	60	50	70	85
Factor for cracked concrete		k_{cr}	[-]	7,7					
Factor for non-cracked concrete		k_{ucr}	[-]	11,0					
Spacing		$s_{cr,N}$	[mm]	144	120	180	150	210	254
Edge distance		$c_{cr,N}$	[mm]	72	60	90	75	105	127
Spacing (splitting)		$s_{cr,sp}$	[mm]	192	160	240	200	280	340
Edge distance (splitting)		$c_{cr,sp}$	[mm]	96	80	120	100	140	170
Partial safety factor		$\gamma_{Msp}^{2)}$	[-]	1,5					

¹⁾ Pull-out failure is not decisive

²⁾ In absence of other national regulations

³⁾ The installation safety factor of $\gamma_{inst} = 1,0$ is included

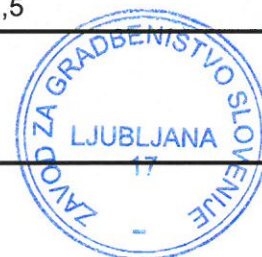

**EJOT through bolts BA-V Plus/ BA-F Plus/ BA-E Plus/
BA-E Plus HCR**

Performance

Characteristic resistance under tension loads

Annex C1

Table C2: Characteristic resistances under shear loads in case of static and quasi-static loading for design according to EOTA TR 055 or **EN 1992-4:2018**

EJOT through bolts BA-V Plus/ BA-F Plus/ BA-E Plus/ BA-E Plus HCR				Anchor size					
				M8	M10- red	M10	M12- red	M12	M16
Steel failure without lever arm									
Characteristic resistance	BA-V Plus/ BA-F Plus	$V_{Rk,s}$	[kN]	12,6	20,4	20,4	30,0	30,0	54,1
	BA-E Plus/ BA-E Plus HCR			15,8			34,4	34,4	68,6
Partial safety factor		$\gamma_{Ms}^{1)}$	[-]	1,25					
Factor for considering ductility		k_7	[-]	1,0					
Steel failure with lever arm									
Characteristic resistance	BA-V Plus/ BA-F Plus	$M^0_{Rk,s}$	[Nm]	26,3	51	51	90	90	219,8
	BA-E Plus/ BA-E Plus HCR			25,1			90	90	214,8
Partial safety factor		$\gamma_{Ms}^{1)}$	[-]	1,25					
Concrete pryout failure									
k-factor		k_8	[-]	1,94	3,31	3,31	2,84	2,84	2,71
Partial safety factor		$\gamma_{Mc}^{1)}$	[-]	1,5					
Concrete edge failure									
Effective length of anchor under shear load		l_f	[mm]	48	40	60	50	70	85
Outside diameter of anchor		d_{nom}	[mm]	8	10		12		16
Cracked concrete without any edge reinforcement		$\Psi_{re,V}$	[-]	1,0					
Cracked concrete with straight edge reinforcement > Ø12 mm				1,2					
Cracked concrete with edge reinforcement and closely spaced stirrups (a ≤ 100mm) or non-cracked concrete				1,4					
Partial safety factor		$\gamma_{Mc}^{1)}$	[-]	1,5					

¹⁾ In absence of other national regulations

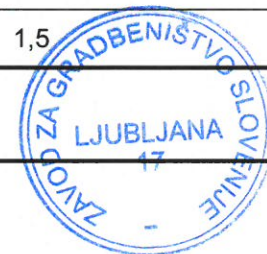

EJOT through bolts BA-V Plus/ BA-F Plus/ BA-E Plus/ BA-E Plus HCR	Annex C2
Performance Characteristic resistance under shear loads	

Table C3: Characteristic resistances under tension loads in case of fire exposure for design according to EOTA TR 020 or **EN 1992-4:2018**

EJOT through bolts BA-V Plus/ BA-F Plus/ BA-E Plus/ BA-E Plus HCR				Anchor size					
				M8	M10-red	M10	M12-red	M12	M16
Steel failure									
Characteristic resistance $N_{Rk,s,fi}$	BA-V Plus/ BA-F Plus	R30	[kN]	1,31	2,09	2,09	3,05	3,05	5,69
		R60	[kN]	1,05	1,66	1,66	2,40	2,40	4,47
		R90	[kN]	0,80	1,24	1,24	1,74	1,74	3,25
		R120	[kN]	0,67	1,02	1,02	1,41	1,41	2,64
	BA-E Plus/ BA-E Plus HCR	R30	[kN]	3,92	6,66	6,66	10,25	10,25	19,09
		R60	[kN]	2,70	4,59	4,59	7,07	7,07	13,16
		R90	[kN]	1,48	2,52	2,52	3,88	3,88	7,23
		R120	[kN]	0,87	1,48	1,48	2,29	2,29	4,26
Pull-out failure									
Characteristic resistance $N_{Rk,p,fi}$	R30	[kN]	2,13	1)	3,00	1)	4,00	6,00	
	R60	[kN]	2,13	1)	3,00	1)	4,00	6,00	
	R90	[kN]	2,13	1)	3,00	1)	4,00	6,00	
	R120	[kN]	1,70	1)	2,40	1)	3,20	4,80	
Concrete cone and splitting failure ²⁾									
Characteristic resistance $N_{Rk,c,fi}^0$	R30	[kN]	2,87	1,82	5,02	3,18	7,38	11,98	
	R60	[kN]	2,87	1,82	5,02	3,18	7,38	11,98	
	R90	[kN]	2,87	1,82	5,02	3,18	7,38	11,98	
	R120	[kN]	2,30	1,46	4,02	2,55	5,90	9,59	
Spacing	$s_{cr,N,fi}$	[mm]	4 x h_{ef}						
	s_{min}	[mm]	35	50	40	55	60	65	
Edge distance	$c_{cr,N,fi}$	[mm]	2 x h_{ef}						
	c_{min}	[mm]	Fire attack from one side: $c_{min} = 2 \times h_{ef}$ Fire attack from more than one side: $c_{min} \geq 300 \text{ mm and } \geq 2 \times h_{ef}$						

¹⁾ Pull-out isn't decisive

²⁾ As a rule, splitting failure can be neglected when cracked concrete and reinforcement is assumed

Design under fire exposure is performed according to the design method given in EOTA TR 020.

Under fire exposure usually cracked concrete is assumed. The design equations are given in EOTA TR 020 § 2.2.1.

In the absence of other national regulations the partial safety factor for resistance under fire exposure $\gamma_{M,fi} = 1,0$ is recommended.

EJOT through bolts BA-V Plus/ BA-F Plus/ BA-E Plus/ BA-E Plus HCR	 Annex C3
Performance Characteristic tension resistance under fire exposure	

Table C4: Characteristic resistances under shear loads in case of fire exposure for design according to EOTA TR 020 or EN 1992-4:2018

EJOT through bolts BA-V Plus/ BA-F Plus/ BA-E Plus/ BA-E Plus HCR				Anchor size					
				M8	M10-red	M10	M12-red	M12	M16
Steel failure without lever arm									
Characteristic resistance $V_{Rk,s,fi}$	BA-V Plus/ BA-F Plus	R30	[kN]	1,31	2,09	2,09	3,05	3,05	5,69
		R60	[kN]	1,05	1,66	1,66	2,40	2,40	4,47
		R90	[kN]	0,80	1,24	1,24	1,74	1,74	3,25
		R120	[kN]	0,67	1,02	1,02	1,41	1,41	2,64
	BA-E Plus/ BA-E Plus HCR	R30	[kN]	3,92	6,66	6,66	10,25	10,25	19,09
		R60	[kN]	2,70	4,59	4,59	7,07	7,07	13,16
		R90	[kN]	1,48	2,52	2,52	3,88	3,88	7,23
		R120	[kN]	0,87	1,48	1,48	2,29	2,29	4,26
Steel failure with lever arm									
Characteristic resistance $M^0_{Rk,s,fi}$	BA-V Plus/ BA-F Plus	R30	[Nm]	0,38	1,12	1,12	2,62	2,62	6,66
		R60	[Nm]	0,34	0,97	0,97	1,97	1,97	4,99
		R90	[Nm]	0,26	0,75	0,75	1,70	1,70	4,33
		R120	[Nm]	0,19	0,60	0,60	1,31	1,31	3,33
	BA-E Plus/ BA-E Plus HCR	R30	[Nm]	0,75	1,87	1,87	3,93	3,93	9,99
		R60	[Nm]	0,60	1,50	1,50	3,28	3,28	8,32
		R90	[Nm]	0,45	1,20	1,20	2,62	2,62	6,66
		R120	[Nm]	0,38	1,05	1,05	2,10	2,10	5,33
Concrete pryout failure									
k-factor	k_8	[-]	1,0	1,0	2,0	1,0	2,0	2,0	
Characteristic resistance $V_{Rk,cp,fi}$	R30	[kN]	2,87	1,82	10,04	3,18	14,76	23,96	
	R60	[kN]	2,87	1,82	10,04	3,18	14,76	23,96	
	R90	[kN]	2,87	1,82	10,04	3,18	14,76	23,93	
	R120	[kN]	2,30	1,46	8,04	2,55	11,80	19,18	
Concrete edge failure									
The initial value $V^0_{Rk,c,fi}$ of the characteristic resistance in concrete C20/25 to C50/60 under fire exposure may be determined by:									
$V^0_{Rk,c,fi} = 0,25 \times V^0_{Rk,c} (\leq R90) \quad V^0_{Rk,c,fi} = 0,20 \times V^0_{Rk,c} (R120)$									
with $V^0_{Rk,c}$ initial value of the characteristic resistance in cracked concrete C20/25 under normal temperature.									

Design under fire exposure is performed according to the design method given in EOTA TR 020.

Under fire exposure usually cracked concrete is assumed. The design equations are given in EOTA TR 020 § 2.2.1.

EOTA TR 020 covers design for fire exposure from one side. For fire attack from more than one side the edge distance must be increased to $c_{min} \geq 300$ mm and $\geq 2 \times h_{ef}$.

In the absence of other national regulations the partial safety factor for resistance under fire exposure $\gamma_{M,fi} = 1,0$ is recommended.

**EJOT through bolts BA-V Plus/ BA-F Plus/ BA-E Plus/
BA-E Plus HCR**

Performance

Characteristic shear resistance under fire exposure

Annex C4

Table C5: Displacements under tension loads for static and quasi-static loading

EJOT through bolts BA-V Plus/ BA-F Plus/ BA-E Plus/ BA-E Plus HCR			Anchor size					
			M8	M10- red	M10	M12- red	M12	M16
Cracked C20/25 – C50/60	N	[kN]	4,1	4,3	5,7	6,1	7,6	11,4
	$\bar{\delta}_{N0}$	[mm]	0,981	0,494	0,619	0,541	0,241	0,777
	$\bar{\delta}_{N\infty}$	[mm]	1,470	0,976	1,367	0,981	1,263	2,211
Non-cracked C20/25 - C50/60	N	[kN]	5,2	5,7	9,0	8,5	11,9	17,1
	$\bar{\delta}_{N0}$	[mm]	0,188	0,064	0,270	0,052	0,105	0,135
	$\bar{\delta}_{N\infty}$	[mm]	1,470	0,976	1,367	0,981	1,263	2,211

Table C6: Displacements under shear loads for static and quasi-static loading

Cracked and non-cracked concrete C20/25 - C50/60			Anchor size					
			M8	M10- red	M10	M12- red	M12	M16
EJOT through bolts BA- V Plus/ BA-F Plus	V	[kN]	7,2	10,5	10,5	16,4	16,4	30,9
	$\bar{\delta}_{V0}$	[mm]	1,090	1,943	0,680	2,438	2,127	2,778
	$\bar{\delta}_{V\infty}$	[mm]	1,635	2,914	1,020	3,657	3,191	4,167
EJOT through bolts BA- E Plus/ BA-E Plus HCR	V	[kN]	9,0	10,5	10,3	16,4	16,4	39,2
	$\bar{\delta}_{V0}$	[mm]	1,653	1,943	0,680	2,438	2,127	3,441
	$\bar{\delta}_{V\infty}$	[mm]	2,480	2,914	1,020	3,657	3,191	5,162



EJOT through bolts BA-V Plus/ BA-F Plus/ BA-E Plus/ BA-E Plus HCR	Annex C5
Performance Displacements under tension and shear loads	

Table C7: Characteristic resistances in case of seismic action for design acc. EOTA TR 045: Performance Category C1 and C2

EJOT through bolts BA-V Plus/ BA-F Plus/ BA-E Plus/ BA-E Plus HCR				Anchor size			
				M8	M10	M12	M16
Tension - steel failure							
Characteristic resistance C1		$N_{Rk,s,seis,C1}$	[kN]	15,0		-	-
Characteristic resistance C2	BA-V Plus	$N_{Rk,s,seis,C2}$	[kN]	-	26,0	39,0	73,0
	BA-E Plus/ BA-E Plus HCR	$N_{Rk,s,seis,C2}$	[kN]	-	26,0	40,0	73,0
Partial safety factor		$\gamma_{Ms,seis}^{1)}$	[-]	1,4			
Tension - pull-out failure							
Characteristic resistance C1	BA-V Plus	$N_{Rk,p,seis,C1}$	[kN]	8,5		-	-
	BA-E Plus/ BA-E Plus HCR	$N_{Rk,p,seis,C1}$	[kN]	8,4		-	-
Characteristic resistance C2	BA-V Plus	$N_{Rk,p,seis,C2}$	[kN]	-	2,7	2,8	10,2
	BA-E Plus/ BA-E Plus HCR	$N_{Rk,p,seis,C2}$	[kN]	-	3,2	3,3	11,1
Partial safety factor		$\gamma_{Mp,seis}^{1)}$	[-]	1,5 ²⁾			
Concrete cone and splitting failure³⁾							
Effective anchorage depth		h_{ef}	[mm]	48	60	70	85
Partial safety factor		$\gamma_{Mc,seis}^{1)}$ $\gamma_{Msp,seis}^{1)}$	[-]	1,5 ²⁾			
Shear - steel failure without lever arm							
Characteristic resistance C1	BA-V Plus	$V_{Rk,s,seis,C1}$	[kN]	8,1		-	-
	BA-E Plus/ BA E Plus HCR	$V_{Rk,s,seis,C1}$	[kN]	7,9		-	-
Characteristic resistance C2	BA-V Plus	$V_{Rk,s,seis,C2}$	[kN]	-	8,5	13,8	30,7
	BA-E Plus/ BA-E Plus HCR	$V_{Rk,s,seis,C2}$	[kN]	-	9,4	14,4	30,8
Partial safety factor		$\gamma_{Ms,seis}^{1)}$	[-]	1,25			
Concrete pryout and concrete edge failure³⁾							
Effective anchorage depth		h_{ef}	[mm]	48	60	70	85
Partial safety factor		$\gamma_{Mc,seis}^{1)}$	[-]	1,5 ²⁾			

¹⁾ In absence of other national regulations

²⁾ The installation safety factor of $\gamma_2 = 1,0$ is included

³⁾ For concrete cone, splitting, pryout and edge failure, see EOTA TR 045



**EJOT through bolts BA-V Plus/ BA-F Plus/ BA-E Plus/
BA-E Plus HCR**

Performance

Characteristic resistances under seismic action
Performance category C1 and C2

Annex C6

Table C8: Displacements in case of seismic action for design acc. EOTA TR 045: Performance Category C2

EJOT through bolts BA-V Plus/ BA-F Plus/ BA-E Plus/ BA-E Plus HCR				Anchor size			
				M8	M10	M12	M16
Displacement under tension loads							
Displacement DLS	BA-V Plus	$d_{N,seis}$	[mm]	-	3,1	5,6	4,0
	BA-E Plus/ BA-E Plus HCR	$d_{N,seis}$	[mm]	-	2,8	6,0	4,7
Displacement ULS	BA-V Plus	$d_{N,seis}$	[mm]	-	10,7	16,7	14,0
	BA-E Plus/ BA-E Plus HCR	$d_{N,seis}$	[mm]	-	6,8	15,5	15,1
Displacement under shear loads							
Displacement DLS	BA-V Plus	$d_{V,seis}$	[mm]	-	3,9	3,6	3,7
	BA-E Plus/ BA-E Plus HCR	$d_{V,seis}$	[mm]	-	4,5	4,7	3,9
Displacement ULS	BA-V Plus	$d_{V,seis}$	[mm]	-	5,8	5,3	6,8
	BA-E Plus/ BA-E Plus HCR	$d_{V,seis}$	[mm]	-	7,6	7,5	7,7

EJOT through bolts BA-V Plus/ BA-F Plus/ BA-E Plus/ BA-E Plus HCR	 Annex C7
Performance Displacements under seismic action Performance category C2	